



ATTESTATO DI ESAME CE DI TIPO

ATTESTATO DI ESAME CE DI TIPO NR.
EC TYPE EXAMINATION CERTIFICATE No.

I 0190

L'IMQ attesta la conformità ai requisiti essenziali stabiliti dalla Direttiva 95/16/CE del seguente prodotto:

IMQ certifies the compliance with the essential requirements stated by Directive 95/16/EC of the product hereunder:

VALVOLA DI BLOCCO / RUPTURE VALVE

(Categoria, tipo e marchio di fabbrica o commerciale / *Category, type and make or trade name*)

START ELEVATOR HYDRAULIK – MOD./MOD.: 04088/01, 04088/02, 04088/03

(Ulteriori informazioni sono riportate in allegato / *Further information are enclosed*)

Detentore dell'Attestato:

Certificate holder:

**START ELEVATOR HYDRAULIK di Lucchini Pier Guido
29010 INCROCIATA DI CALENDASCO PC**

Costruito da:

Manufactured by:

**START ELEVATOR HYDRAULIK di Lucchini Pier Guido
LOC. INCROCIATA DI CALENDASCO
29010 CALENDASCO PC**

In base all'Allegato V della Direttiva 95/16/CE, il presente Attestato, unitamente al rispetto di una delle procedure ivi previste, consente alla Ditta di apporre sul prodotto sopradescritto la seguente marcatura:

According to the Annex V of the Directive, this Certificate, together with the compliance with one of the procedures therein foreseen allows the firm to affix on the above mentioned product the following marking:



Il numero identificativo dell'IMQ quale organismo notificato è: 0051
The IMQ identification number as notified Body is: 0051

2002-01-28

Milano,
Milan

IMQS.p.A.

Il presente Attestato annulla e sostituisce il precedente
This Certificate cancels and replaces the previous one.

No. I0190 del/of 1998-07-24

IMQ S.p.A. - VIA QUINTILIANO 43 - 20138 MILANO MI - I

ALLEGATO ALL'ATTESTATO DI ESAME CE DI TIPO N. I0190
Annex to EC Type examination Certificate no.

(Seq. Nr. 98001685)

Rapporto di prova n. / Test report no.

50FB00004

Eventuali informazioni supplementari
Additional information

Marca / Trade mark :	START ELEVATOR HYDRAULIK
Modello / Model :	04088 / 02
Flusso nominale minimo / Minimum rated flow:	120 l/min
Flusso nominale massimo / Maximum rated flow:	400 l/min
Pressione statica minima / Minimum static pressure:	10 bar
Pressione statica massima / Maximum static pressure:	50 bar
Viscosità del fluido idraulico minima / Minimum viscosity:	14 cSt
Viscosità del fluido idraulico massima / Maximum viscosity:	290 cSt
Temperatura ambiente minima / Minimum ambient temperature:	10 °C
Temperatura ambiente massima / Maximum ambient temperature:	70 °C

Data di rilascio / Date of issue :	1998-07-24
Aggiornamento / Updating :	2002-01-28
Sostituisce / Supersedes :	1998-07-24 che si intende annullata / which is to be intended withdrawn

ALLEGATO ALL'ATTESTATO DI ESAME CE DI TIPO N. I0190
Annex to EC Type examination Certificate no.
(Seq. Nr. 98001685)

Rapporto di prova n. / Test report no. 50FB00004

Eventuali informazioni supplementari
Additional information

Marca / Trade mark :	START ELEVATOR HYDRAULIK
Modello / Model :	04088 / 03
Flusso nominale minimo / Minimum rated flow:	120 l/min
Flusso nominale massimo / Maximum rated flow:	400 l/min
Pressione statica minima / Minimum static pressure:	10 bar
Pressione statica massima / Maximum static pressure:	50 bar
Viscosità del fluido idraulico minima / Minimum viscosity:	14 cSt
Viscosità del fluido idraulico massima / Maximum viscosity:	290 cSt
Temperatura ambiente minima / Minimum ambient temperature:	10 °C
Temperatura ambiente massima / Maximum ambient temperature:	70 °C

Data di rilascio / Date of issue :	1998-07-24
Aggiornamento / Updating :	2002-01-28
Sostituisce / Supersedes :	1998-07-24 che si intende annullata / which is to be intended withdrawn

ALLEGATO ALL'ATTESTATO DI ESAME CE DI TIPO N. I0190
Annex to EC Type examination Certificate no.
(Seq. Nr. 98001685)

N. DISEGNO / Drawing no.	DESCRIZIONE / Description
04088ND	VALVOLA PISTONE 1"1/2 2001

Allegato note / Annex note

Grafico andamento del flusso fluido idraulico in funzione della pressione all'ingresso e all'uscita della valvola di blocco / *graphic of relationship between flow of hydraulic fluid and pressure before and behind the rupture valve.*

Data di rilascio / *Date of issue* : 1998-07-24
Aggiornamento / *Updating* : 2002-01-28
Sostituisce / *Supersedes* : 1998-07-24 che si intende annullata / *which is to be intended withdrawn*

ALLEGATO ALL'ATTESTATO DI ESAME CE DI TIPO N. I0190
Annex to EC Type examination Certificate no.
(Seq. Nr. 98001685)

RUPTURE VALVE

**RELATIONSHIP BETWEEN
FLOW OF HYDRAULIC FLUID AND PRESSURE**

Manufacturer : **START ELEVATOR HYDRAULIK**
Series : **1"½**
Models : **04088 / 01; 04088 / 02; 04088 / 03.**
Ambient temperature : **10° C**
Pressure : **10 bar**

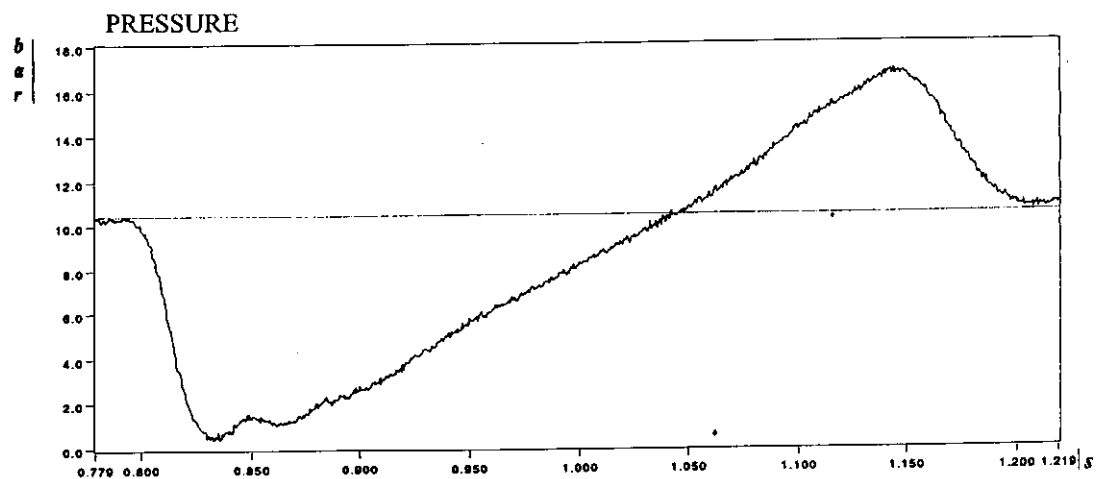
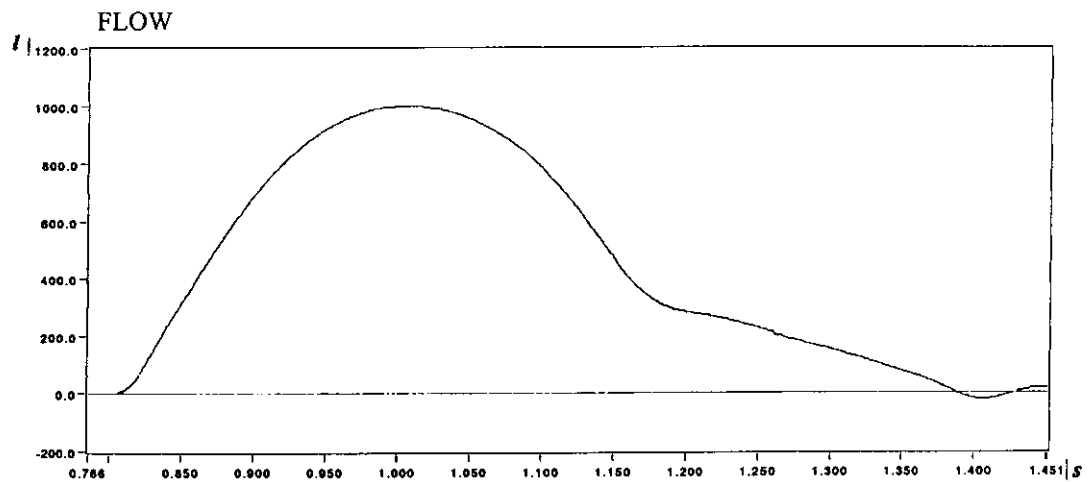

Data di rilascio / Date of issue : 1998-07-24
Aggiornamento / Updating : 2002-01-28
Sostituisce / Supersedes : 1998-07-24 che si intende annullata / which is to be intended withdrawn

Valve Type	Identification	Pump Unit Connection	Nominal Flow L/min min ÷ max	Static Pressure bar min ÷ max	Oil Viscosity cSt min ÷ max
1"1/2	Cod. 04088 01	42 - M 52 x 2	120 ÷ 400	10 ÷ 50	14 ÷ 290
	Cod. 04088 02	Gas 1"1/2			
	Cod. 04088 03	Gas 2"			

screw clockwise
to decrease the intervention flow rate
screw anticlockwise
to increase the intervention flow rate

Schematic Diagram

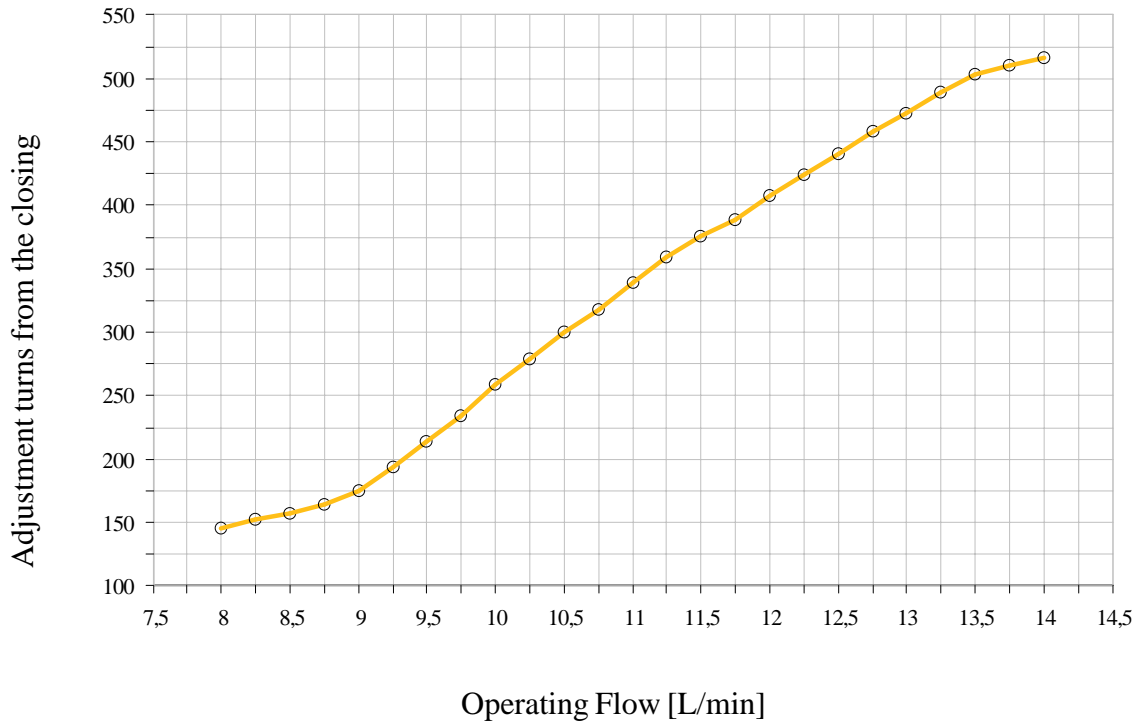
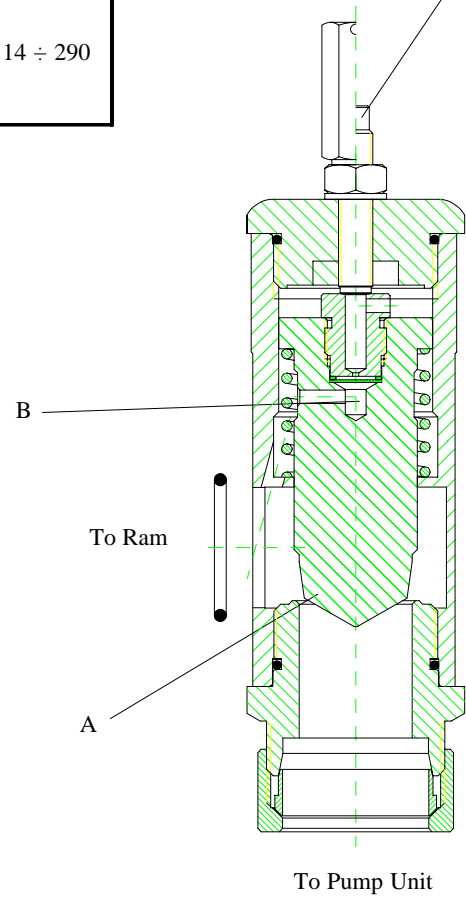
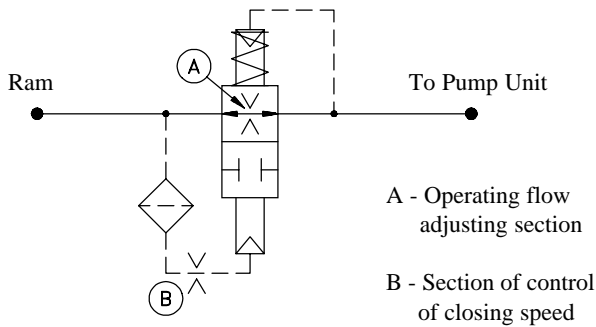

**SAFETY VALVE
ADJUSTING
TYPE 1"1/2**



Start Elevator Hydraulik

08 168 / G

rev. 0

1/2

Valve adjustment instructions

The following tables give instructions to adjust the block valves on the basis of the litres normally used in the pump unit.

If the nominal operating flow rate of the unit is not indicated in the table, see the diagram on sheet 1 to find the right adjustment for the best intervention flow rate.

Once acquainted with the value of the adjusting turns, turn anticlockwise the valve cap, loosen the lock nut and turn clockwise the adjusting screw to the closing valve limit.

Then turn it anticlockwise to reach the adjusting value previously calculated.

Tighten the lock nut and turn the cap clockwise checking if there are oil leakages.

An intervention test is then recommended, following the instructions of the pump unit manufacturer.

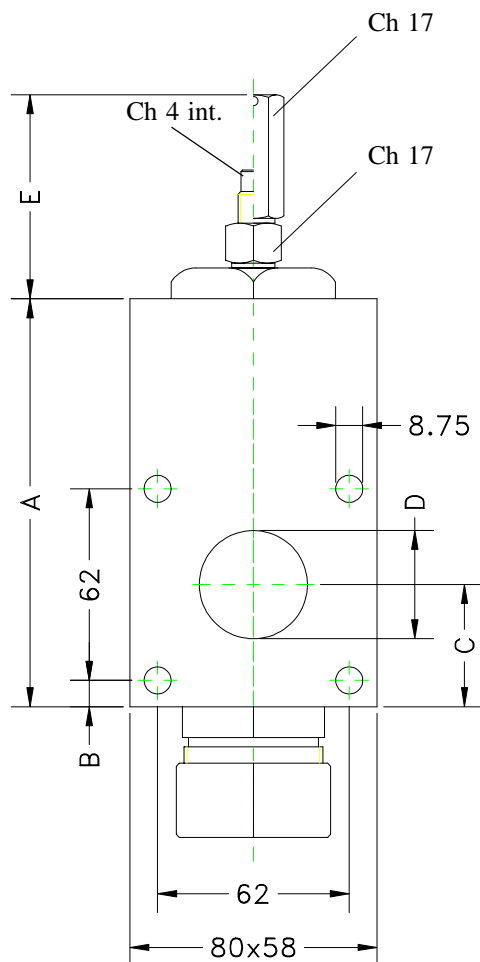

VALVE 1"1/2 ADJUSTMENTS TABLE

Pump litres	Adjust.turns	L/min oper.	increase %
120	8 - 1/4	153	27
150	9 - 1/4	194	29
180	9 - 3/4	235	30
205	10	259	26
250	10 - 3/4	318	27
300	11 - 1/2	376	25
380	13	473	24
400	13 - 1/2	503	25

DIMENSIONS TABLE [mm]

TIPO VALVOLA	1"1/2
A	132
B	9,5
C	40,5
D	35
E	66

**SAFETY VALVE
ADJUSTING
TYPE 1"1/2**



Start Elevator Hydraulik

08 168 / G

rev. 0

2/2